

PCIE2-2710 PCIE GEN2 EXPANSION SYSTEM USER'S MANUAL

The information in this document has been carefully checked and is believed to be entirely reliable. However, no responsibility is assumed for inaccuracies. Furthermore, Cyclone Microsystems, Inc. reserves the right to make changes to any products herein to improve reliability, function, or design. Cyclone Microsystems, Inc. neither assumes any liability arising out of the application or use of any product or circuit described herein, nor does it convey any license under its right or the rights of others.

Revision 1.3, October 2017

Cyclone P/N 800-2710

Copyright 2017 by Cyclone Microsystems, Inc.

CONTENTS



CHAPTER 1

1.1 INTRODUCTION	1-1
1.2 SPECIFICATIONS.....	1-3
1.3 STANDARDS	1-4
1.4 ORDERING INFORMATION.....	1-5

CHAPTER 2

2.1 THEORY OF OPERATION	2-1
-------------------------------	-----

CHAPTER 3

3.1 PCIE2-2710 CHASSIS	3-1
3.2 SEATING OF CARDS	3-1
3.3 CHASSIS COOLING	3-2
3.4 CHASSIS POWER	3-2
3.4.1 1200W Power supply Option	3-2
3.4.2 2180W/3240W Power Supply Options	3-2
3.5 LIGHT LOADING.....	3-2
3.6 POWER CONSIDERATIONS.....	3-3
3.7 PCI-E AUXILIARY POWER CONNECTORS.....	3-4

CHAPTER 4

4.1 SYSTEM POWER UP	4-1
4.2 SEATING OF CARDS	4-1
4.3 PCIe2-426 HOST BUS CABLE ADAPTER	4-1
4.3.1 PCIe2-426 Power	4-1
4.3.2 PCIe2-426 Mechanical	4-1
4.3.3 PCIe2-426 LED Indicators.....	4-1
4.3.4 PCIe2-426 Output Swing, De-Emphasis and Receive Equalization.....	4-2
4.4 PCIE-436 UPSTREAM CABLE ADAPTER	4-2
4.4.1 PCIe-436 Power	4-2
4.4.2 PCIe-436 Mechanical	4-2
4.4.3 PCIe-436 LED Indicators.....	4-3
4.4.4 PCIe-436 Output Swing, De-Emphasis and Receive Equalization.....	4-3
4.5 LINK INDICATION - LED DEFINITION PCIe-429.....	4-3
4.6 SYSTEM MONITOR BOARD.....	4-4

CHAPTER 5

5.1 PHYSICAL CONFIGURATION.....	5-1
---------------------------------	-----

CHAPTER 6

6.1 REFERENCE	6-1
---------------------	-----

LIST OF FIGURES

Figure 1-1. PCIe2-2710 Block Diagram 1-2
Figure 5-1. PCIe2-429 Physical Configuration..... 5-1
Figure 5-2. PCIe2-426 LEDs..... 5-2
Figure 5-3. PCIe2-426 Physical Configuration..... 5-2
Figure 5-4. PCIe-436 LEDs..... 5-3
Figure 5-5. PCIe-436 Physical Configuration..... 5-3
Figure 5-6. PCIe2-2710 5U Chassis 5-4

LIST OF TABLES

Table 1-1. Physical/Environmental Characteristics 1-3
Table 1-2. 3240W N+1 Redundant Power Supply Characteristics 1-3
Table 1-3. 2180W N+1 Redundant Power Supply 1-4
Table 1-4. 1200W Power Supply Characteristics 1-4
Table 3-1. Slot Capabilities 3-1
Table 3-2. 1200W Power Supply Minimum Loading 3-3
Table 3-3. 2180W/3240W Power Supply Minimum Loading 3-3
Table 3-4. PCIe2-429 Power Requirements 3-3
Table 3-5. PCIe2-426 Power Requirements 3-4
Table 3-6. Power Supplied Per PCIe Slot..... 3-4
Table 4-1. PCIe2-426 Default DIP Switch Configuration 4-2
Table 4-2. Link LED Indication..... 4-3

1.1 INTRODUCTION

The Cyclone Microsystems PCIe2-2710 is a PCI Express (PCIe) Gen2 expansion system that allows the user to add up to eight double width PCI Express add-in-cards. Most PCs contain few PCI Express slots making them poorly suited for embedded systems requiring many different I/O boards and co-processor resources. The PCIe2-2710 Expansion System 1200 has been designed for applications using multiple GPUs and other high-powered PCIe devices.

The PCIe2-2710 PCI Express Expansion System permits system developers to use powerful and cost-effective PCs as a foundation for a robust embedded system. The eight PCI Express slots are organized as two x16 slots and six x8 slots and are all Gen2 capable. All expansion slots accommodate double width, full length and full height cards and are cooled by four 77 CFM fans. The PCIe2-2710 is available with either a 3240 W or 2180 W N+1 redundant power supply in a 5U chassis, or a 1200 W standard ATX supply in a 4U chassis.

The Expansion System supports 80 Gb/s bi-directional traffic to and from the host system. The system utilizes repeaters and non-blocking PCI Express switches for excellent peer-to-peer I/O bandwidth. For PCs with modern BIOSs, the PCIe2-2710 Expansion System is recognized by the host system upon boot-up, requires no hardware specific drivers and is entirely host operating system agnostic.

The PCIe2-2710 system is composed of three elements: a PCI Express Host Bus Cable Adapter, an Expansion System Cable and an Expansion Chassis. The PCIe-426 Host Bus Cable Adapter card is to be inserted into a host computer's x16 PCIe Gen2 slot. The x16 PCIe expansion cable links the PCI host with the expansion chassis. The expansion chassis is populated with the PCIe-429 Switched Backplane, the PCIe-436 Upstream Cable Adaptor and, optionally, a System Monitor board.

PCI Express is a high performance, general purpose I/O inter-connect defined for a wide variety of computing and communication platforms. Key PCI attributes, such as its usage model, load-store architecture, and software interfaces are maintained, whereas its parallel bus implementation is replaced by a serial interface. PCI Express take advantage of recent advances in point-to-point inter-connects, switch-based technology, and packetized protocol to deliver new levels of performance.

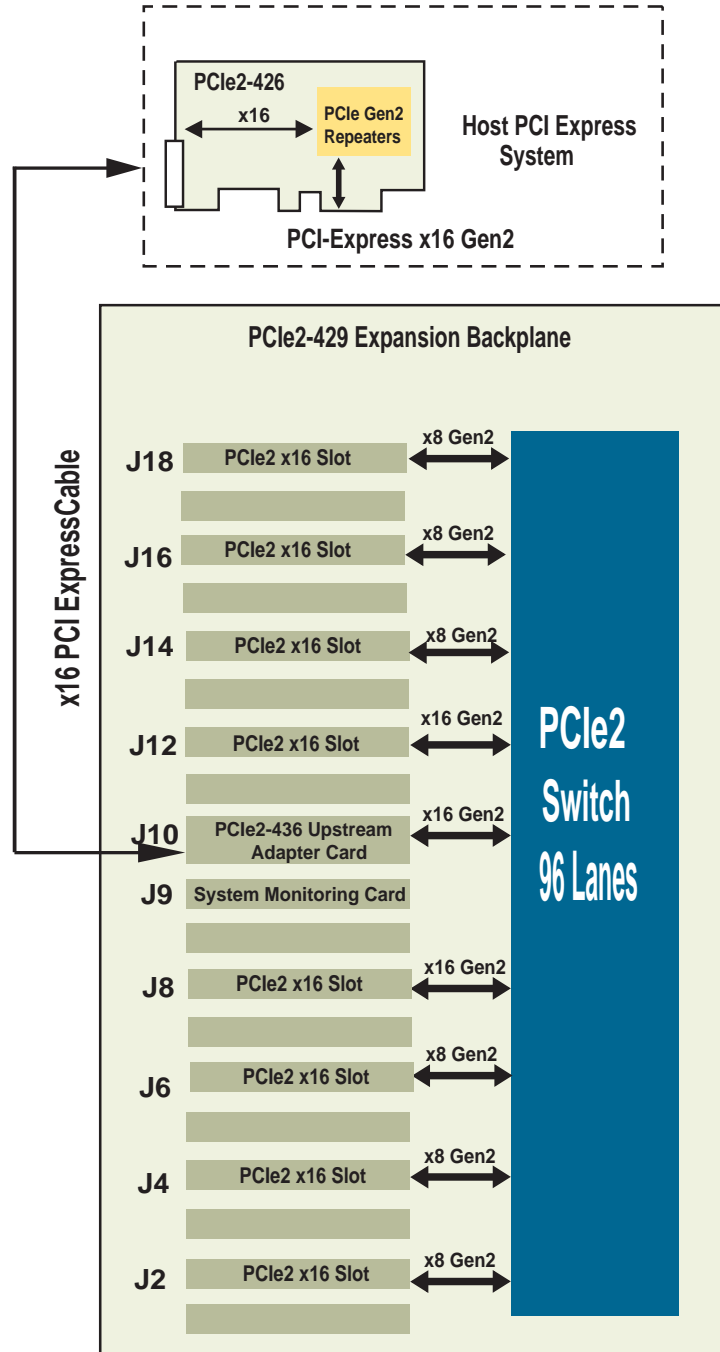

Figure 1-1. PCIe2-2710 Block Diagram

1.2 SPECIFICATIONS

The specifications in Table 1-1 detail the PCIe2-2710 Expansion System chassis including the PCIe-429 expansion backplane, PCIe-436 Upstream Cable Adaptor and chassis/power supply. The chassis also includes four 77 CFM fans.

Table 1-1. Physical/Environmental Characteristics

Height	8.75 inches (5U Chassis) 7 inches (4U Chassis)
Width	17 inches
Depth	27 inches
Weight	80 lbs (5U chassis) 50 lbs (4U chassis)
Operating Temperature	0 to 50 Degrees Celsius
Relative Humidity	0% to 95% (non-condensing)
Storage Temperature	-20 to 70 Degrees Celsius

Table 1-2. 3240W N+1 Redundant Power Supply Characteristics

Voltage	90-264 VAC		
Frequency	47-63 Hz.		
Input Current	45A (115 VAC), 22.5A (240 VAC)		
Maximum Inrush Current	30A (115 VAC), 15A (230 VAC) per Module		
Total DC Output	3240W		
DC Output Specs	Output Voltage	Output Current Min	Output Current Max
	+5V	1	24
	+12V	6	263
	-12V	0	1.5
	+3.3V	1	24
	+5VSB	0.1	4

Table 1-3. 2180W N+1 Redundant Power Supply

Voltage	90-264 VAC		
Frequency	47-63 Hz.		
Input Current	30A (115 VAC), 15A (230 VAC)		
Maximum Inrush Current	30A (115 VAC), 15A (230 VAC) per Module		
Total DC Output	2180W		
DC Output Specs	Output Voltage	Output Current Min	Output Current Max
	+5V	1	24
	+12V	6	178
	-12V	0	1.5
	+3.3V	1	24
	+5VSB	0.1	4

Table 1-4. 1200W Power Supply Characteristics

Voltage	90-264 VAC		
Frequency	47-63 Hz.		
Input Current	15A (100 VAC), 7.5A (240 VAC)		
Maximum Inrush Current	50A (115 VAC), 100A (230 VAC)		
Total DC Output	1200W		
DC Output Specs	Output Voltage	Output Current Min	Output Current Max
	+5V	0	25
	+12V	0.6	100
	-12V	0	0.5
	+3.3V	0	25
	+5VSB	0	3

1.3 STANDARDS

PCI Express Base Specification Revision 2.0

PCI Express Card Electro Mechanical Specification 2.0

PCI Express External Cabling Specification 2.0

1.4 ORDERING INFORMATION

The expansion system is available with one or three meter cable, standard or low profile panels on the Host Bus Adaptor (PCIe-426), 1200W, 2180W or 3240W power supply, and the optional Chassis Monitor board.

Cyclone Part Numbers	
600-2710-1-12-S	Expansion System with 1 meter cable and 1200W Power Supply (4U chassis)
600-2710-3-12-S	Expansion System with 3 meter cable and 1200W Power Supply (4U chassis)
600-2710-1-21-S	Expansion System with 1 meter cable and 2180W Power Supply (5U chassis)
600-2710-3-21-S	Expansion System with 3 meter cable and 2180W Power Supply (5U chassis)
600-2710-1-32-S	Expansion System with 1 meter cable and 3240W Power Supply (5U chassis)
600-2710-3-32-S	Expansion System with 3 meter cable and 3240W Power Supply (5U chassis)

2.1 THEORY OF OPERATION

The basic PCI Express link consists of dual unidirectional differential links, implemented as a transmit pair and a receive pair. The signaling rate for PCI Express Gen2 is 5.0 Gigabits/second/Lane/direction. A link supports at least one lane.

The PCI Express link from the PCIe-426 over the cable to the PCIe-429 is a sixteen lane (x16) link. The PCIe-429 provides two x16 slots (slots J8 and J12) and six x8 slots (slots J2, J4, J6, J14, J16, J18). All slots are populated mechanically with x16 connectors; the upper eight lanes of slots J2, J4, J6, J14, J16, J18 are not connected. All slots can accommodate either single lane (x1), x4, x8 or x16 add-in cards. Although not expressly permitted by the PCI Express Specification, slots J2, J4, J6, J14, J16, J18 accommodate “down-shifting” a x16 card into a x8 slot. Plugging a smaller link card into a larger link connector is fully allowed.

Once the PCIe-426 is installed into the host PC, the cable connected to the PCIe2-2710 chassis, the chassis plugged into an AC power outlet and any desired add-in cards are installed, the system is ready to be turned on. When the host is turned on, a signal from the PCIe-426 will turn on the PCIe2-2710 chassis. A number of things happen at this point. First, the PCI Express links are initialized. This is a purely hardware initialization where each PCI Express link is set up following a negotiation of lane widths by the two ends of each link. No firmware or operating system software is involved. Once the links are initialized or “trained”, there are LED indicators on each of the Cyclone Microsystems cards that indicate the links are trained. A detailed explanation of the LEDs follows later in this manual.

One essential requirement for system initialization is the ability of the host system’s BIOS to be able to enumerate the many bridges inherent in a complex PCI Express design. The links from the PCIe-426 to the PCIe-429 are created with PCI Express Switches. Each link looks like a PCI-to-PCI bridge to the Host’s BIOS. The number of bridges can add up quickly. Older BIOS may not have the resources to enumerate the number of bridges. Make sure that the BIOS on the host computer has the latest updated BIOS. If required, contact the host system’s manufacturer to make sure that the BIOS used can handle the large number of bridges that it will see in the system.

3.1 PCIE2-2710 CHASSIS

The PCIe-429 Expansion Backplane is installed into a 20-slot rack-mountable chassis. Depending on the power supply configuration, the chassis is either 4U (1200W single supply), or 5U (2180W or 3240W, N+1 redundant supply). The chassis also contains multiple drive bays that may be used to install peripheral devices for specific applications.

3.2 SEATING OF CARDS

Unlike standard PC applications, the PCIe2-2710 Expansion Systems has a narrow lower gate that precisely engages the lower end of the PCI Express Add-In board's face panel. The purpose is to ensure correct electrical connector mating of up-plugged boards. Failure to accurately mate the lower end of the face panel with the chassis lower gate will lead to the board not being recognized by the host.

Table 3-1. Slot Capabilities

Slot	Connector	Lanes	Width
J2	x16 connector	x8 lanes	double
J4	x16 connector	x8 lanes	double
J6	x16 connector	x8 lanes	double
J8	x16 connector	x16 lanes	double
J9	x1 connector	Monitor Slot	single
J10	x16 connector	Upstream Cable Slot	single
J12	x16 connector	x16 lanes	double
J14	x16 connector	x8 lanes	double
J16	x16 connector	x8 lanes	double
J18	x16 connector	x8 lanes	double

All eight slots of the PCIe-429 have x16 connectors but only slots J8 and J12 have the full x16 lane connection to the switch. The remaining slots (J2, J4, J6, J14, J16, J18) have a x8 lane connection to the switch. All slots will support a double width PCIe add-in card such as a graphics board or GPU with a heat sink. Slots J9 and J10 use PCIe slot connectors but have proprietary pinouts and are not for general purpose use. Slot J10 is for the Upstream Cable Adaptor, slot J9 is for the optional System Monitor board. Only Cyclone Microsystems Upstream Cable Adaptors and System Monitor boards should be installed in slots J10 and J9 respectively. Table 3-1 summarizes the slot capabilities

3.3 CHASSIS COOLING

Airflow in the PCIe2-2710 chassis is provided by four 77 CFM fans located midship across the full width of the chassis.

3.4 CHASSIS POWER

There are three different power supply options available for the PCIe2-2710. The 1200W option provides ample power for the backplane and low-powered PCIe devices. The 2180W and 3240W options provide N+1 redundancy, and are intended for high-powered, multi-GPU applications.

3.4.1 1200W Power Supply Option

The 4U chassis option is powered by a front-mounted 1200W single mini-ATX power supply. Power entry is cabled to a receptacle located at the rear of the chassis. The supply outputs are modular, providing the 24-pin ATX, 8-pin EPS and 4-pin EPS power connectors required by the PCIe-428 backplane. The 1200W supply can be configured to also provide up to eight 6+2 pin PCIe power connectors for use the GPUs and other high powered PCIe cards, as well as eleven Serial ATA power connectors for disk drives and other peripheral devices.

3.4.2 2180W/3240W Power Supply Options

The 5U chassis option is powered by an N+1 redundant supply providing either 2180W or 3240W of total power. Four individual power supply units reside across the bottom rear of the chassis and slide into the redundant power supply housing. In this configuration, any one power supply module can fail and the chassis will still provide full power capacity.

Should one power supply unit fail, an alarm will sound. The supplies are hotswappable; an individual supply can be replaced while the unit remains powered on. Removing an individual supply is done by loosening the thumb screw, then pushing outwards on the release tab while pulling the supply out of the housing. Replacement power supply units are available from Cyclone.

The N+1 redundant supplies provide one 24-pin ATX power connector and two 8-pin EPS connectors that power the PCIe-429 backplane. Additionally, the supplies provide eight six-pin PCIe power connectors, and eight six-plus-two pin PCIe power connectors for use with GPUs and other high-powered PCIe cards. There are also provides six SerialATA connectors for powering disk drives and other peripheral devices.

NOTE: Users should be aware that 2180W or 3240W systems may exceed the power available from a standard 15A or 20A AC circuit. When connecting to the AC mains, care should be taken to use multiple AC circuits. Otherwise, problems with tripping circuit breakers can result.

3.5 LIGHT LOADING

Because the power supply has been sized for a fully populated chassis, when placed under light loading, the supply may not stay in regulation. Symptoms of a supply that is not regulating properly are loss of link back to the host (“CABLE LINK” LEDs are not ON) or a chassis that powers up momentarily, then turns OFF.

Users of the N+1 chassis or those using their own chassis and power supplies need to be aware of the minimum loading requirements. The 1200W chassis minimum loading can be met by using the on-board jumpers. The N+1 chassis will need to have cards installed to meet the +12V minimum loading. Table 3-2 and Table 3-3 summarize the minimum loading requirements.

Table 3-2. 1200W Power Supply Minimum Loading

Voltage	Minimum Load	Status
+5VSB	0A	One board circuitry meets power supply minimum.
+5V	0A	One board circuitry meets power supply minimum.
+3.3V	0A	One board circuitry meets power supply minimum.
+12V	0.6A	Jumpers Z3 and Z4 can be used to meet power supply minimum, 0.5A per jumper.

Table 3-3. 2180W/3240W Power Supply Minimum Loading

Voltage	Minimum Load	Status
+5VSB	0.1A	One board circuitry meets power supply minimum.
+5V	1A	Install Jumper Z5 to meet power supply minimum.
+3.3V	1A	On board circuitry meets power supply minimum.
+12V	6A	Cards must be installed to meet minimum load. Jumpers Z3 and Z4 can be used to help meet power supply minimum, 0.5A per jumper.

3.6 POWER CONSIDERATIONS

Table 3-4 through 3-6 show the power consumption for the Cyclone Microsystems boards and the power supplied to PCI Express slots. Note that the PCIe-426 is installed in and powered by the host supply. Consequently, the PCIe-426 should not be included as a component of the Expansion Chassis power budget.

Table 3-4. PCIe- 429 Power Requirements

Voltage	Current Typical	Current Maximum	Note
+5VSB	0.1A	0.1A	Not used. On board circuitry sets current draw.
+5V	0.5A	1A	Not used. On board circuitry draws 0.5A and Jumper Z5 can add another 0.5A.
+3.3V	1.5A	1.5A + 24A	Maximum is PCIe-429 circuitry plus 8 slots x 3A per slot =24A.
+12V	1A	2A + 44A	Maximum is PCIe-429 circuitry plus 8 slots x 5.5A per slot = 44A.

Table 3-5. PCIe- 426 Power Requirements

Voltage	Current Typical	Current Maximum
+3.3V	1.09 Amps	1.60 Amps
+12V	0 Amps	0 Amps

* The PCIe-426 does not use +12V

Table 3-6. Power Supplied Per PCIe Slot

Voltage	Current Maximum	Voltage Tolerance
+3.3V	3.0 Amps	+/- 9%
+12V	5.5 Amps	+/- 8%

3.7 PCI-E AUXILIARY POWER CONNECTORS

Some PCIe add-in cards, especially video cards, require more power than the PCIe spec of 75W per slot can provide. These cards will have a six or eight position Molex type power connector probably located at the top or rear edge of the card. The power supply in the expansion chassis has at least eight PCIe auxiliary power cables labeled “PCI-E” available for these card types. GPU card users should verify that all external power connections to their cards have been made.

4.1 SYSTEM POWER UP

The host PC with the PCIe-426 installed controls power-up for the entire system. The PCI Express cable should be connected between the PCIe-426 and the PCIe-436/PCIe-429 and the PCIe2-2710 power cords should be connected to the chassis and plugged into power outlets. There is a power button on the front of the PCIe2-2710 Expansion Chassis, however, it is not connected and serves no practical purpose in this application. When the host PC is powered on, a signal is sent over the PCI Express cable to turn on the PCIe2-2710. If the chassis does not power up, make sure that all cards are seated properly, the chassis is plugged in and the PCI Express cable is connected properly. There is only one LED on the front of the expansion chassis that has meaning. The green LED indicates that the chassis is powered.

4.2 SEATING OF CARDS

Unlike standard PC applications, the PCIe2-2710 Expansion System has a narrow lower gate that precisely engages the lower end of the PCI Express Add-In board's face panel. The purpose is to ensure correct electrical connector mating of up-plugged boards. Failure to accurately mate the lower end of the face panel with the chassis lower gate will lead to the board not being recognized by the host.

4.3 PCIe-426 HOST BUS CABLE ADAPTER

The PCIe-426 Host Bus Cable Adapter is installed in a host computer's x16 Gen2 slot providing an interface from the host to the x16 cable and, in turn, the expansion chassis. It can also be plugged into Gen1 x16 slots, reducing performance.

4.3.1 PCIe-426 Power

The PCIe-426 only uses +3.3V power from the host, see Table 3-2.

4.3.2 PCIe-426 Mechanical

The PCIe-426 is a low profile PCI Express add-in card and is available with either a standard height front panel or a low profile front panel. See Figure 5-3 for a mechanical drawing of the card and Figure 5-2 for a front panel drawing.

4.3.3 PCIe-426 LED Indicators

The bottom (or left) LED on the front panel is the "Cable Present Detect" LED. This LED reflects the status of the "CPRSNT#" signal in the PCIe Expansion Cable. When the LED is ON, it is indicating that the "CPRSNT#" signal is asserted. The PCIe-429 chassis asserts "CPRSNT#" to indicate that it is present, the cable is connected and power is good. If this LED is OFF, there may be a problem with +3.3V power in the expansion chassis or the PCIe Expansion Cable is not connected properly.

The top (or right) LED on the panel is "Expansion System Signal Detect". The LED is on when the PCIe-426 detects a signal on Lanes 0-3 of the PCIe cable. The LED ON indicates normal operation. If the LED is not on, there is something wrong with the cable or the expansion system is not operating properly.

4.3.4 PCIe-426 Output Swing, De-Emphasis and Receive Equalization

The transceiver silicon used on the PCIe-426 has eight steps of programmable de-emphasis, four steps of output swing and eight steps of receive equalization. The PCIe-426 has three DIP switches to adjust these settings on the cable interface. The as-shipped-default DIP switch configuration is what Cyclone Microsystems has determined is the best setting for Gen1 or Gen2 operation with both the 1m and 3m PCIe cables shipped with Cyclone PCIe Expansion systems. Users should not change the DIP switch settings unless they have the proper test equipment to verify their results. Users change de-emphasis, output swing and receive equalization at their own peril. The default DIP switch configuration is shown below:

Table 4-1. PCIe-426 Default DIP Switch Configuration

POSITION	SWITCH S1	SWITCH S2	SWITCH S3
1	OFF	OFF	ON
2	OFF	ON	ON
3	ON	ON	ON
4	ON	ON	OFF

4.4 PCIe-436 UPSTREAM CABLE ADAPTER

The cable interface for the expansion chassis is the PCIe-436 Upstream Cable Adapter. It is only installed in slot J10 of the PCIe-429.

4.4.1 PCIe-436 Power

The PCIe-436 only uses +3.3V power from the expansion chassis.

4.4.2 PCIe-436 Mechanical

The PCIe-436 has the same outline as a low profile x16 PCI Express add-in card but it is not, it has a proprietary pin out and should be installed **ONLY** in slot J10 of the PCIe-429. See Figure 5-4 for a front panel drawing of the card and Figure 5-5 for a mechanical drawing.

4.4.3 PCIe-436 LED Indicators

The bottom (or left) LED on the front panel is the "Cable Present Detect" LED. This green LED reflects the status of the "CPRSNT#" signal in the PCIe Expansion Cable. When the LED is ON, it is indicating that the "CPRSNT#" signal is asserted. The PCIe-429 chassis asserts "CPRSNT#" to indicate that it is present, the cable is connected and power is good. If this LED is OFF, there may be a problem with +3.3V power in the expansion chassis or the PCIe Expansion Cable is not connected properly.

The top (or right) LED on the panel is a "PCIe Link Indicator". This yellow LED is ON solid when all cable lanes used and are operating at Gen2 rates. A cable link running at Gen1 rates and/or using less lanes than available will indicate status with a blinking LED. The blinking pattern is the same as the slot indicators, see Table 4-2.

4.4.4 PCIe-436 Output Swing, De-Emphasis and Receive Equalization

The transceiver silicon used on the PCIe-436 has eight steps of programmable de-emphasis, four steps of output swing and eight steps of receive equalization. The as-shipped-default configuration of the transceiver silicon is what Cyclone Microsystems has determined is the best setting for Gen2 operation with both 1m and 3m PCIe cables shipped with Cyclone PCIe Expansion systems. This configuration will also function adequately for Gen1 operation.

4.5 LINK INDICATION - LED DEFINITION PCIe-429

The PCIe-429 has seventeen green LEDs to indicate the link status of each slot and the cable. Each slot and has two, redundant, LED link status indicators. Nine surface mount LEDs, one for each slot and one for the cable, are arranged in a row in the corner of the board where the cable enters, see Figure 5-2. The LEDs are labeled J2, J4, J6, J8, J12, J14, J16, J18 and CABLE.

Eight surface mount LEDs are placed adjacent to each slot. The LEDs are placed just off axis to the bottom side of an installed board so as not to be obscured by components on the board. The LEDs are labeled SLOT J2 through SLOT J18.

A fully functional link (all lanes used and operating at Gen2 rates) will have its LED ON solid. A link running at Gen1 rates and/or using less lanes than available will indicate status with a blinking LED. The LEDs indicate link status as follows:

Table 4-2. Link LED Indication

OFF	Link is down
ON	Link is up, all lanes, Gen2 (5GT/s) rate.
BLINK: 0.5 seconds ON, 0.5 seconds OFF	Link is up, reduced lanes, Gen2 (5GT/s rate)
BLINK: 1.5 seconds ON, 0.5 seconds OFF	Link is up, all lanes, Gen1 (2.5GT/s rate).
BLINK: 0.5 seconds ON, 1.5 seconds OFF	Link is up, reduced lanes, Gen1 (2.5GT/s rate).

4.6 SYSTEM MONITOR BOARD

The PCIe2-2710 system has an optional System Monitor board. It has the same outline and profile as a x1 PCI Express add-in card but it is not, it has a proprietary pin out and should be installed **ONLY** in slot J9 of the PCIe-429. As it's name suggests, the System Monitor board watches the operation of the cooling fans, temperature at multiple board locations and the voltage of power supply rails and locally created voltages on the expansion board.

The monitor board has an ethernet port allowing the expansion chassis to be placed on a network where users can then remotely check expansion system status.

5.1 PHYSICAL CONFIGURATION

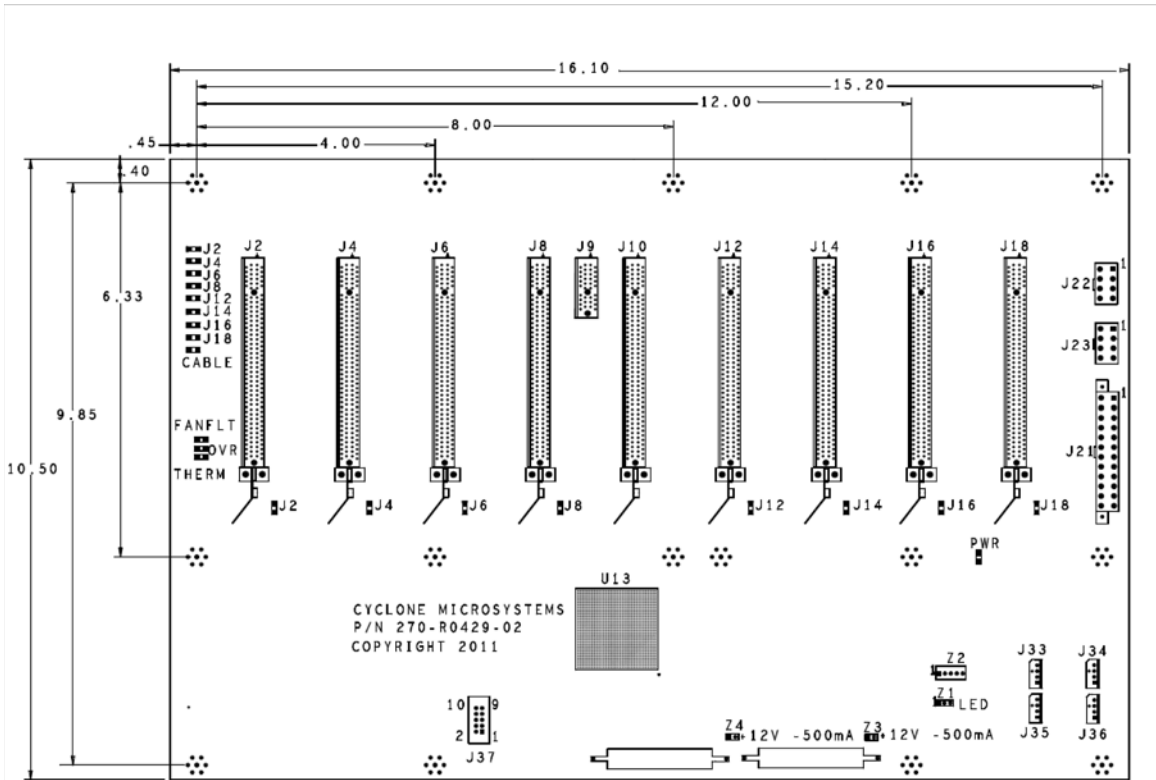

** Dimensions in Inches**

Figure 5-1. PCIe-429 Physical Configuration

Figure 5-1 is a physical diagram (not to scale) of the PCIe-429 backplane, showing the location designators of jumpers, connectors, and major ICs. Refer to this figure when component locations are referenced in the manual text.

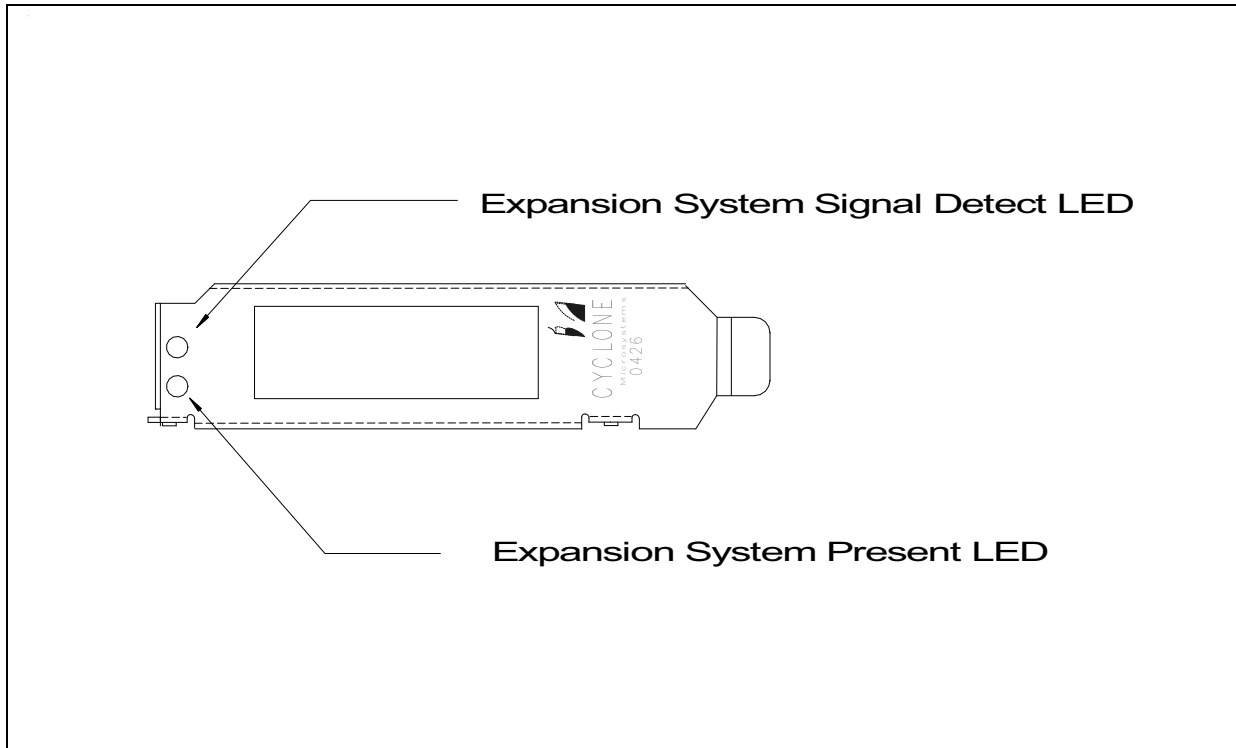

Figure 5-2. PCIe-426 LEDs

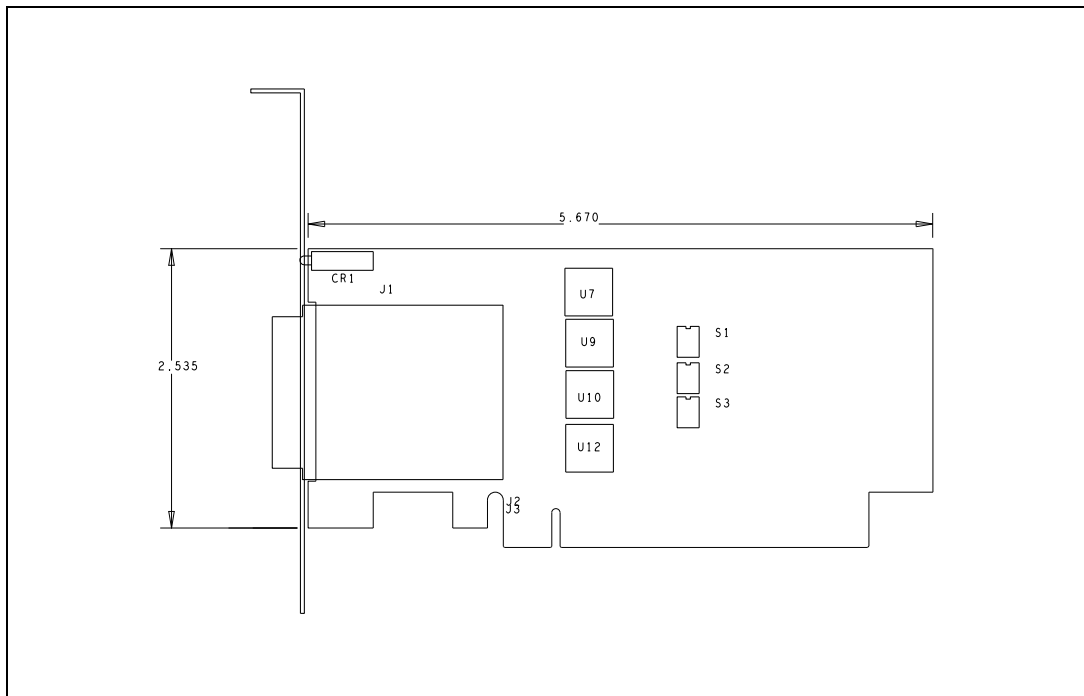

Figure 5-3. PCIe-426 Physical Configuration

Figure 5-4. PCIe-436 LEDs

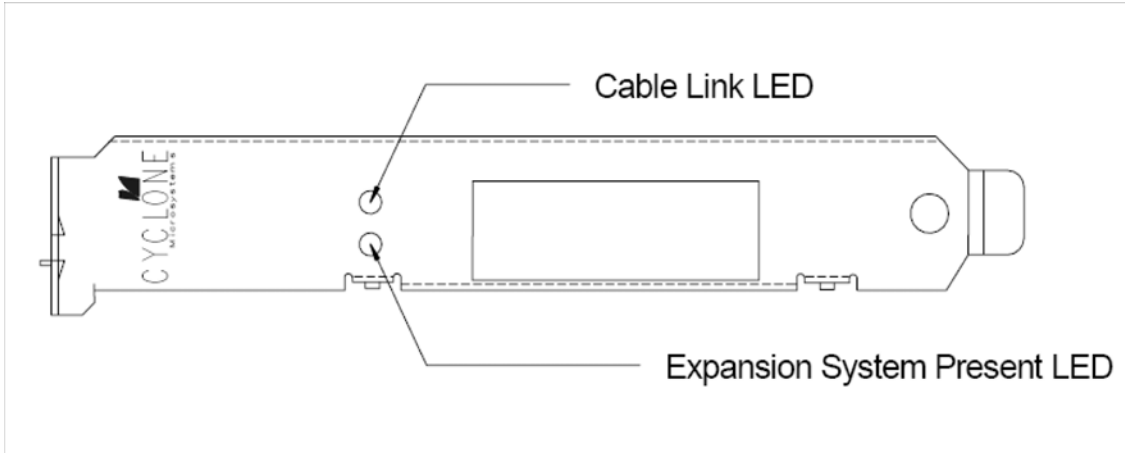

Figure 5-5. PCIe-436 Physical Configuration

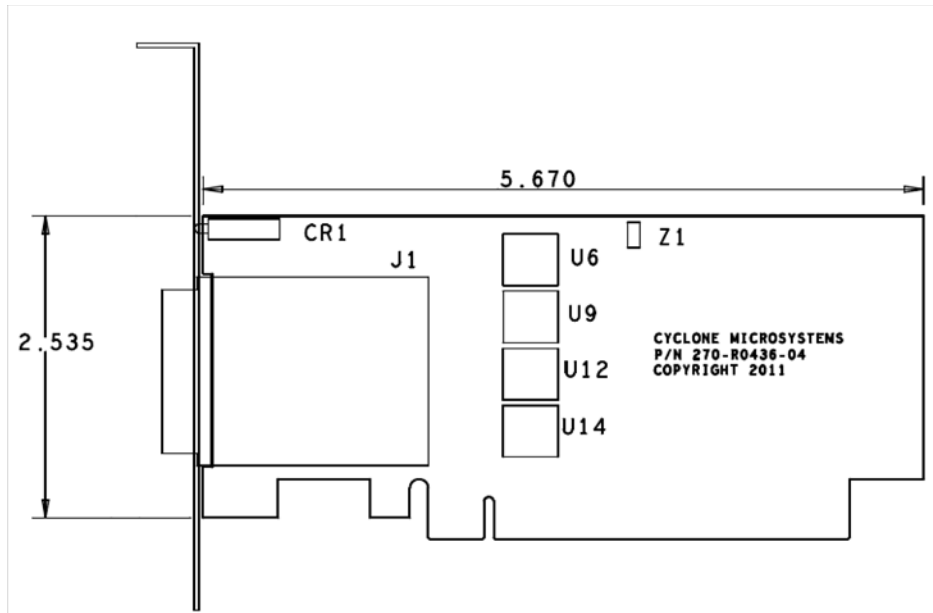



Figure 5-6. PCIe2-2710 5U Chassis

6.1 REFERENCE MANUALS

PEX 8696 96-Lane, 24-Port PCI Express Gen2 Multi-Root Switch Data Book Version 1.3

PLX Technology, Inc.

Sunnyvale, CA

(800) 759-3735

www.plxtech.com

PCI Express Base Specification Revision 2.0

PCI Express Card Electromechanical Specification Revision 2.0

PCI Express External Cabling Specification Revision 2.0

PCI Special Interest Group (PCISIG)

5440 SW Westgate Dr., #217 Portland OR 97221

(503) 291-2569

(503) 297-1090 (Fax)

www.pcisig.org