

# **2400-28 FRONT END PROCESSOR MAINTENANCE & SUPPORT GUIDE**

The information in this document has been carefully checked and is believed to be entirely reliable. However, no responsibility is assumed for inaccuracies. Furthermore, Cyclone Microsystems, Inc. reserves the right to make changes to any products herein to improve reliability, function, or design. Cyclone Microsystems, Inc. neither assumes any liability arising out of the application or use of any product or circuit described herein, nor does it convey any license under its right or the rights of others.

Revision 1.0, July 2003

Cyclone P/N 800-2400-28

Copyright 2003 by Cyclone Microsystems, Inc.

**CHAPTER 1**

1.1 INTRODUCTION..... 1-1  
 1.2 SPECIFICATIONS..... 1-1

**CHAPTER 2**

2.1 PHYSICAL CONFIGURATION..... 2-1  
 2.2 SWITCHES..... 2-5  
   2.2.1 FEP Power Supply Switches..... 2-5  
   2.2.2 FEP Reset Switch..... 2-5  
 2.3 CONNECTORS ..... 2-5  
   2.3.1 Power Connector..... 2-5  
     2.3.1.1 DC Power Connectors (600-2400-28-D0) ..... 2-5  
     2.3.1.2 AC Power Connectors (600-2400-28-A0) ..... 2-6  
     2.3.1.3 Ground Studs ..... 2-7  
   2.3.2 CPCI-810 Console Connector ..... 2-7  
   2.3.3 Ethernet Port Connector..... 2-7  
   2.3.4 TDM E1 Port Connectors ..... 2-8

**CHAPTER 3**

3.1 FEP INITIALIZATION AND BUILT-IN SELF TEST ..... 3-1

**CHAPTER 4**

4.1 PERIODIC MAINTENANCE..... 4-1

**CHAPTER 5**

5.1 SERVICEABLE COMPONENTS..... 5-1  
 5.2 BOARD REMOVAL AND INSTALLATION ..... 5-1  
   5.2.1 Board Removal..... 5-1  
   5.2.2 Board Installation..... 5-2  
 5.3 FAN TRAY REMOVAL AND INSTALLATION..... 5-2  
   5.3.1 Fan / Filter Assembly Removal..... 5-2  
   5.3.2 Fan/Filter Assembly Installation..... 5-2  
 5.4 POWER SUPPLY REMOVAL AND INSTALLATION..... 5-2  
   5.4.1 Power Supply Removal ..... 5-2  
   5.4.2 Power Supply Installation ..... 5-2

**CHAPTER 6**

6.1 METHODOLOGY..... 6-1  
 6.2 ASSUMPTIONS ..... 6-1  
 6.3 CONFIGURATION ..... 6-2  
 6.4 RESULTS..... 6-2

**CHAPTER 7**

7.1 OVERVIEW..... 7-1  
 7.2 HARDWARE..... 7-1  
 7.3 SOFTWARE AND FIRMWARE ..... 7-1

**CONTENTS**



7.4 EFFECTIVE PERIOD OF WARRANTY ..... 7-1  
7.5 REPAIRED OR REPLACEMENT PRODUCT (OUT-OF-WARRANTY)..... 7-1  
7.6 SERVICE POLICY..... 7-2

**APPENDIX A**

A.1 ADDITIONAL INFORMATION..... A-1

**LIST OF FIGURES**

Figure 1-1. FEP Part Numbering ..... 1-1

Figure 2-1. 600-2400-28-D0 FEP Front Panel..... 2-1

Figure 2-2. 600-2400-28-A0 FEP Front Panel..... 2-2

Figure 2-3. 600-2400-28 FEP Front Panel LEDs..... 2-3

Figure 2-4. DC Power Connector..... 2-6

Figure 2-5. AC Power Connector ..... 2-6

Figure 2-6. 75ohm BNC Connector ..... 2-8

Figure 4-1. Air Filter Replacement ..... 4-2

**LIST OF TABLES**

Table 1-1. 600-2400-28 Specifications ..... 1-2

Table 2-1. 600-2400-28-D0 FEP Front Panel Description..... 2-1

Table 2-2. 600-2400-28-A0 FEP Front Panel Description..... 2-2

Table 2-3. 600-2400-28 FEP Front Panel LED Description..... 2-3

Table 2-4. Ring Lugs for #10 Studs..... 2-7

Table 2-5. Console Port Connector ..... 2-7

Table 2-6. Ethernet Port Connector..... 2-8

Table 2-7. TDM E1 Port 0 Connector Pin Assignments ..... 2-8

Table 2-8. TDM E1 Port 1 Connector Pin Assignments ..... 2-9

Table 2-9. TDM E1 Port 2 Connector Pin Assignments ..... 2-9

Table 2-10. TDM E1 Port 3 Connector Pin Assignments ..... 2-9

Table 3-1. CPCI-816 Initialization LED Pattern Description ..... 3-1

Table 4-1. Air Filter Replacement ..... 4-1

Table 5-1. CLEI Number and Barcode ..... 5-1

## 1.1 INTRODUCTION

The 2400-28 Front End Processor is a system featuring four time division multiplexed (TDM) E1 links and two Ethernet ports. The TDM links run at 2.048Mbps. The system uses two PowerPC processors. The 2400-28 is available in AC or DC versions and features two redundant, hot swappable power supplies. The 2400-28 system also monitors power supply, fan status and temperature in an effort to detect and provide early alert to component failures.

The part numbering system for the 600-2400 series of FEPs is as shown in Figure 1-1.

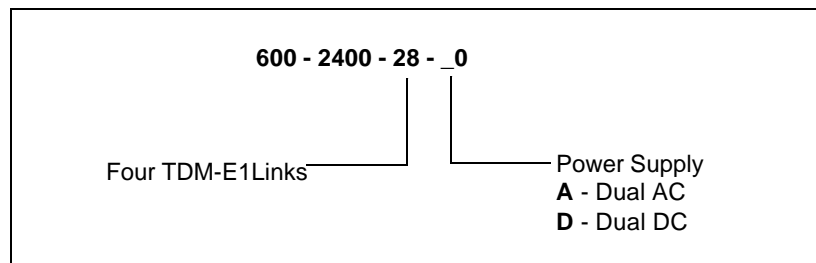

**Figure 1-1. FEP Part Numbering**

## 1.2 SPECIFICATIONS

Table 1-1 lists the specifications for the 2400-28 series Front End Processor. Cooling air input is on the left side of the unit and the air exhaust is on the right side. Airflow should not be restricted; a minimum of one inch clearance on each side is required.

**Table 1-1. 600-2400-28 Specifications**

<b>Physical</b>	Height	5.25 inches
	Width	17.5 inches
	Depth	12 inches
	Other	19 inch rack mountable
	Weight	15 lbs
<b>Electrical - AC version</b>	<b>(600-2400-28-A0)</b>	
	Voltage:	90 - 264 Vac
	Current (Max):	3A
	Power Dissipation:	175 BTU/hr.
	Frequency:	47 - 63 Hz
	Connector: Ethernet ports: Console serial ports: E1 ports:	10/100 BaseTx RJ45 RJ11 75ohm BNC, Transmit/Receive
<b>Electrical - DC version</b>	<b>(600-2400-28-D0)</b>	
	Voltage:	36 - 72 Vdc
	Current (Max):	6.5A
	Power Dissipation:	175 BTU/hr.
	Connector: Ethernet ports: Console Serial ports E1 ports:	10/100 BaseTx RJ45 RJ11 75 ohm BNC, Transmit/Receive

<b>Environmental</b>	Operating Temperature	0 to 55 Degrees Celsius
	Relative Humidity	0% to 95% (non-condensing)
	Storage Temperature	-55 to 125 Degrees Celsius
<b>Regulatory Compliance</b>	UL1950	
	<p>CUL C22.2 No. 950, CE Marking, FCC Class A</p> <p><u>Note:</u> This equipment has been tested and found to comply with the limits for a Class A digital device, pursuant to Part 15 of the FCC Rules. These limits are designed to provide reasonable protection against harmful interference when the equipment is operated in a commercial environment. This equipment generates, uses and can radiate radio frequency energy and, if not installed and used in accordance with the instruction manual, may cause harmful interference to radio communications. Operation of this equipment in a residential area is likely to cause harmful interference in which case the user will be required to correct the interference at his own expense.</p> <p><u>Caution:</u> Changes or modifications to this equipment not expressly approved by the party responsible for compliance could void the user's authority to operate the equipment.</p> <p>This digital apparatus does not exceed the Class A limits for radio noise emissions from digital apparatus set out in the Radio Interference Regulations of the Canadian Department of Communication.</p> <p>The equipment or subassembly is suitable for connection to intra-building or no exposed wiring or cabling only.</p> <p>Le present appareil numerique n'emet pas de bruits radioelectriques dépassant les limites applicables aux appareils numeriques de las classe A prescrites dans le Reglement sur le brouillage radioelectrique edicte par le ministere des Communications du Canada.</p>	

**2.1 PHYSICAL CONFIGURATION**

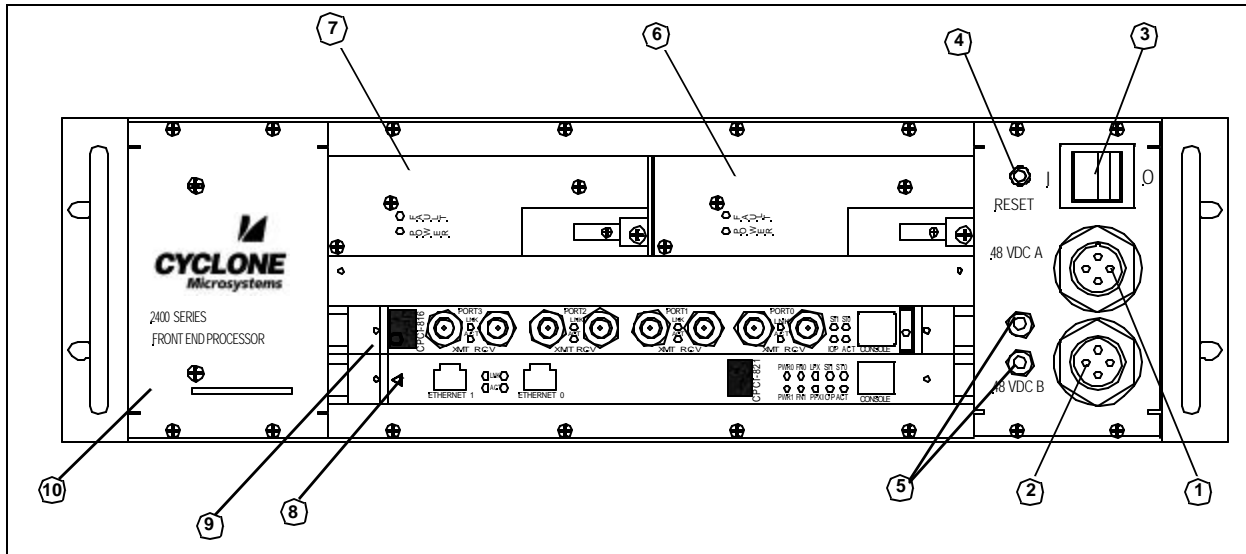

**Figure 2-1. 600-2400-28-D0 FEP Front Panel**

Figure 2-1 shows a front view of the FEP unit with DC power supplies. Table 2-1 identifies each item.

**Table 2-1. 600-2400-28-D0 FEP Front Panel Description**

No.	SLOT#	Name
1		Power Connector A
2		Power Connector B
3		FEP Power supply ON/OFF Switch
4		FEP Reset Switch
5		FEP Ground Lugs
6		Power Supply A
7		Power Supply B
8	0	CPCI-821
9	1	CPCI-816
10		Fan/Filter Assembly



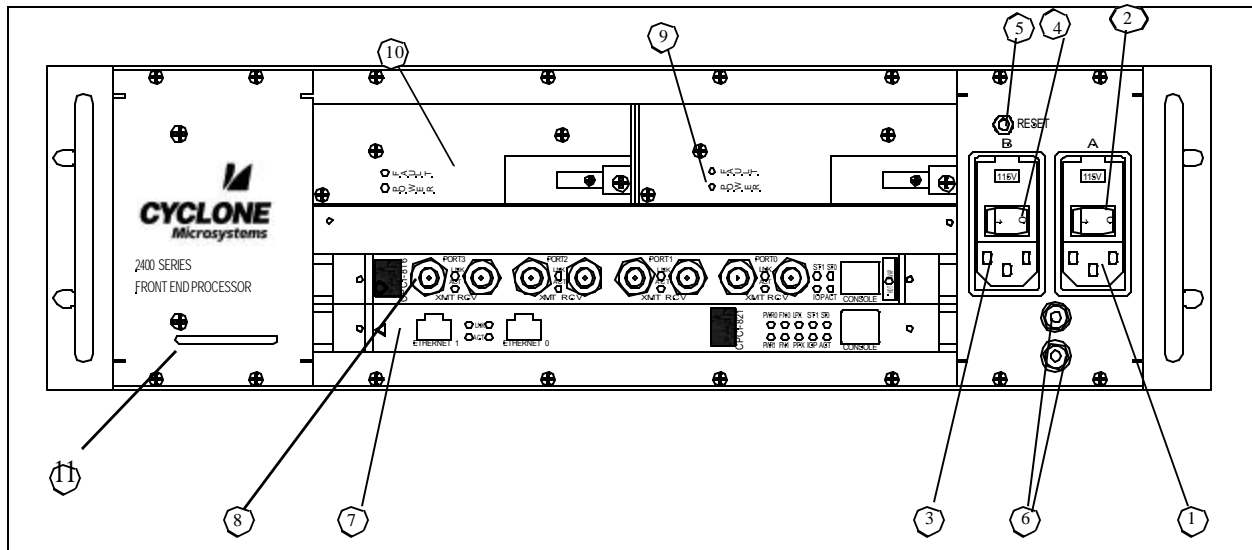
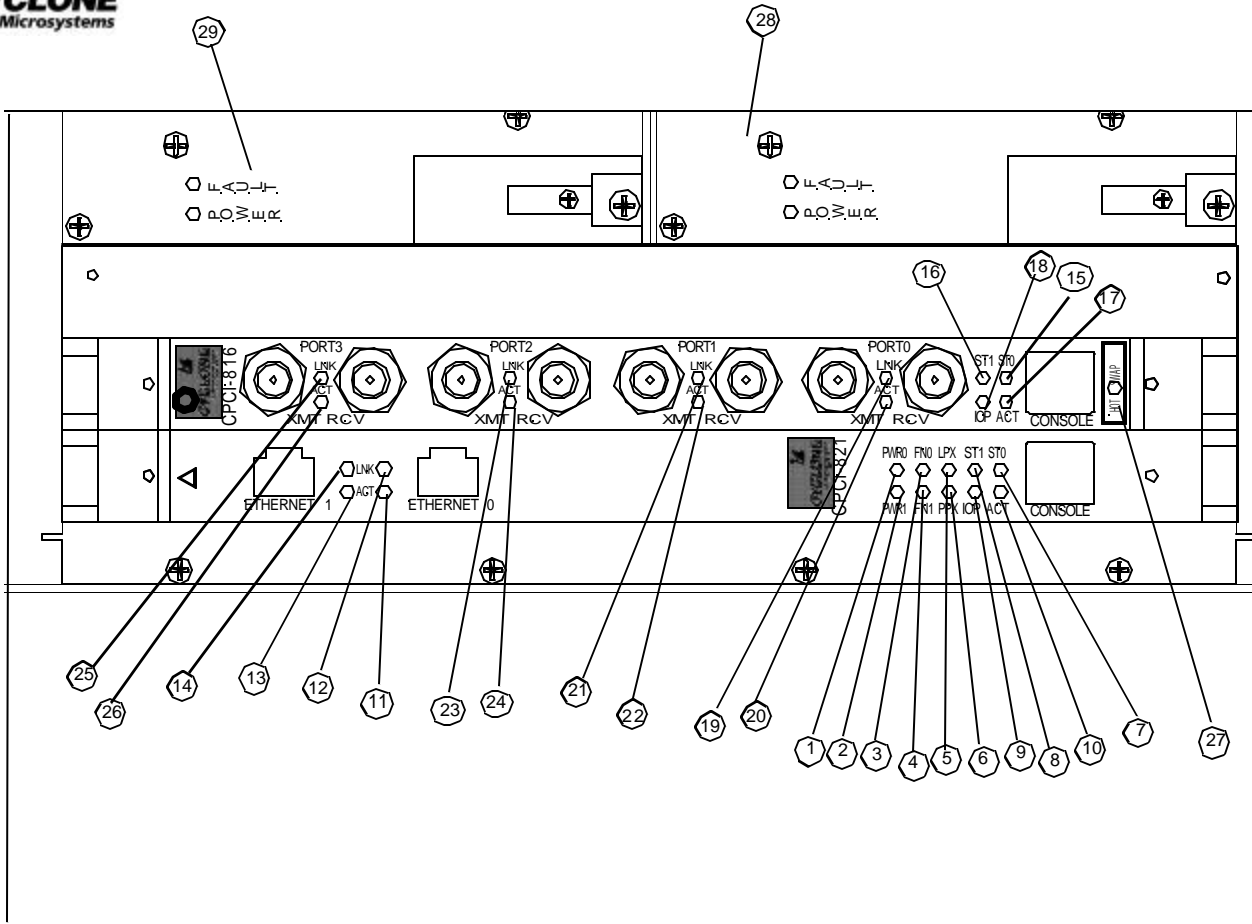

**Figure 2-2. 600-2400-28-A0 FEP Front Panel**

Figure 2-2 shows a front view of the FEP unit with AC power supplies. Table 2-2 identifies each item.

**Table 2-2. 600-2400-28-A0 FEP Front Panel Description**

No.	SLOT#	Name
1		Power Connector A
2		FEP Power supply ON/OFF Switch A
3		Power Connector B
4		FEP Power supply ON/OFF Switch B
5		FEP Reset Switch
6		FEP Ground Lugs
7	0	CPCI-821
8	1	CPCI-816
9		Power Supply A
10		Power Supply B
11		Fan/Filter Assembly



**Figure 2-3. 600-2400-28 FEP Front Panel LEDs**

Figure 2-3 shows a front view of the FEP unit. Table 2-3 briefly describes each item.

**Table 2-3. 600-2400-28 FEP Front Panel LED Description**

No.	SLOT#	Name	Description
1	0	CPCI-821 PWR0	Turns on and remains on for power good condition of power supply A and turns off for power failure.
2	0	CPCI-821 PWR1	Turns on and remains on for power good condition of power supply B.
3	0	CPCI-821 FN0	Turns on and remains on for FAN0 good condition and turns off for FAN0 failure.
4	0	CPCI-821 FN1	Turns on and remains on for FAN1 good condition and turns off for FAN1 failure.
5	0	CPCI-821 LPX	Turns on and remains on for local PCI bus running PCI-X and turns off for local PCI bus not running PCI-X
6	0	CPCI-821 PPX	Turns on and remains on for Compact PCI bus running PCI-X and turns off for Compact PCI bus not running PCI-X.
7	0	CPCI-821 ST0	Indicates status 0 for CPCI-821 and will light And remain on for some time after a reset or power-on and turn off.

## CONFIGURATION & CONNECTORS



8	0	CPCI-821 ST1	Indicates status 1 for CPCI-821 and will light and remain on for some time after a reset or power-on and turn off.
9	0	CPCI-821 IOP	Indicates IOP for CPCI-821 and will light for a short time after a reset or power on and then turn off.
10	0	CPCI-821 ACT	Indicates CPCI-821 activity and will blink and/or vary in intensity as CPCI-821 performs different operations.
11	0	CPCI-821 Ethernet 0 ACT	Indicates network activity for port 0 and will blink during transmit and receive activity.
12	0	CPCI-821 Ethernet 0 LNK	Indicates link integrity for Ethernet port 0 and will remain on continuously if port 0 is connected to a functional network or Ethernet port.
13	0	CPCI-821 Ethernet 1 ACT	Indicates network activity for port 1 and will blink during transmit and receive activity.
14	0	CPCI-821 Ethernet 1 LNK	Indicates link integrity for Ethernet port 1 and will remain on continuously if port 1 is connected to a functional network or Ethernet port.
15	0	CPCI-816 ST0	Indicates status 0 for CPCI-816 and will light for a short time after reset or power-on, then turn off.
16	1	CPCI-816 ST1	Indicates status 1 for CPCI-816 and will light for a short time after reset or power-on and then turn off.
17	1	CPCI-816 ACT	Indicates CPCI-816 activity and will remain on for some time then turn off after reset or power-on.
18	1	CPCI-816 IOP	Indicates IOP for CPCI-816 and will light for a short time after reset or power-on and then turn off.
19	1	CPCI-816 Port 0 LNK	Indicates a valid link for TDM E1 Port 0.
20	1	CPCI-816 Port 0 ACT	Indicates activity on TDM E1 Port 0 link.
21	1	CPCI-816 Port 1 LNK	Indicates a valid link for TDM E1 Port 1.
22	1	CPCI-816 Port 1 ACT	Indicates activity on TDM E1 Port 1 link.
23	1	CPCI-816 Port 2 LNK	Indicates a valid link for TDM E1 Port 2.
24	1	CPCI-816 Port 2 ACT	Indicates activity on TDM E1 Port2 link.
25	1	CPCI-816 Port 3 LNK	Indicates a valid link for TDM E1 Port 3.
26	1	CPCI-816 Port 3 ACT	Indicates activity on TDM E1 Port 3 link.
27	1	CPCI-816 Hot Swap	This will illuminate when it is permissible to extract the CPCI-816. It also lights at power-up and during reset.
28	1	Power Supply A	The FEP Power Supply green 'POWER' LED is located on the power supply. It illuminates when the power supply is ON. The yellow 'FAULT' LED will light while the power supply is hot swapped, or if the power supply is faulty, or if there is no power supplied to the power entry module.
29		Power Supply B	The FEP Power Supply green 'POWER' LED is located on the power supply. It illuminates when the power supply is ON. The yellow 'FAULT' LED will light while the power supply is hotswapped or if the power supply is faulty, or if there is no power supplied to the power entry module.

**2.2 SWITCHES**

**2.2.1 FEP Power Supply Switches**

The 600-2400-28-D0 DC unit has a single power switch. This switch enables and disables power from both power entries to both power supplies. The '1' position indicates power supply ON and '0' position indicates power supply OFF.

The 600-2400-28-A0 AC unit has two power switches, each switch associated with one of the power entry modules. AC power switch A enables and disables power entry to power supply A and AC power switch B enables and disables power entry to power supply B.

**2.2.2 FEP Reset Switch**

The FEP Reset Switch is a momentary push-button switch that resets the FEP.

**2.3 CONNECTORS**

**2.3.1 Power Connector**

There are two power supply connectors on the right hand side of the FEP.

**2.3.1.1 DC Power Connectors (600-2400-28-D0)**

The DC power connector is military style circular bayonet connector with the contact arrangement and pin assignment as shown in Figure 2-4. Mating connector part numbers, backshell part numbers and cable clamp backshell part numbers are as follows:

<b>Manufacturer</b>	<b>Mating Connector</b>	<b>Backshell</b>	<b>Cable Clamp Backshell</b>
ITT Cannon	MS 3476 W14 4S MS 3475 W14 4S	057-0718-002	057-0685-002
Deutsch	MS 3476 W14 4S	94002-14-3014	94002-14-3014

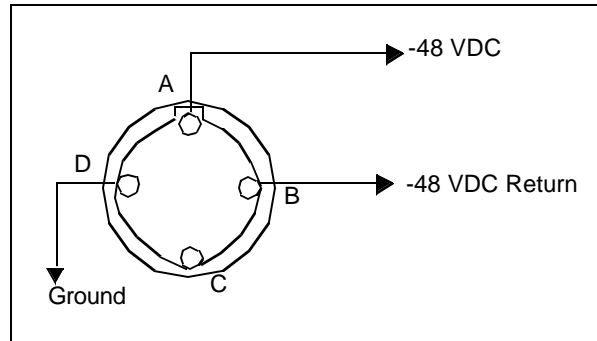

**Figure 2-4. DC Power Connector**

The DC power wiring harness to 600-2400-28-D0 should use 14 AWG wire and the color code as follows:

Color	Signal	Contact
Red	-48 VDC	A
Black	-48 VDC Return	B
Green/Yellow	Chassis ground	D

**2.3.1.2 AC Power Connectors (600-2400-28-A0)**

The AC power connector is a 3-pin connector. See Figure 2-5.

The power Connector is a standard IEC type recessed power receptacle.

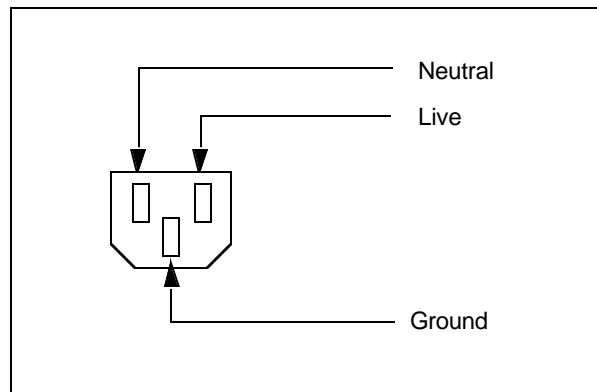

**Figure 2-5. AC Power Connector**

**2.3.1.3 Ground Studs**

There are two #10-32 threaded studs (with hex nuts, flat washers and star washers included) attached to the chassis of the 600-2400-28-A0 and 600-2400-28-D0. Ring lugs should be used to attach chassis ground to the ground studs. Table 2-4 shows AMP/Tyco part numbers for typical ring lugs for #10 studs.

**Table 2-4. Ring Lugs for #10 Studs**

Wire Gauge	AMP/Tyco Part
14-16 AWG	320630
10-12 AWG	36161

**2.3.2 CPCI-821 Console Connector**

The CPCI-821 Console Connector is a narrow RJ11 (6 positions) phone jack. The console port is an RS232 serial port using a simple three-wire connection (transmit data, receive data & ground). The connector assignment is as shown in Table 2-5. Normal system operation does not require a connection to the CPCI-821 console connector.

Diagnostic or debug activity may require connecting to the CPCI-821 console connector. A cable connecting the console port to a standard DB25 connector is available from Cyclone Microsystems (P/N 530-2006). A terminal (or PC running a terminal emulation program) should be set up for any baud up to 115K baud, 8 bits, no parity and 1 stop bit.

**Table 2-5. Console Port Connector**

Pin	Signal	Description
1	-	N/C
2	GND	Ground
3	TXD	Transmit Data
4	RXD	Receive Data
5	-	N/C
6	-	N/C

**2.3.3 Ethernet Port Connector**

The Ethernet Ports Connector 10/100 Base TX is a shielded RJ45 phone jack. The pin assignments are as shown in Table 2-6.

**Table 2-6. Ethernet Port Connector**

Pin	Signal	Description
1	TX+	Transmit + (output)
2	TX-	Transmit - (output)
3	RX+	Receive + (input)
4	-	N/C
5	-	N/C
6	RX-	Receive - (input)
7	-	N/C
8	-	N/C

**2.3.4 TDM E1 Port Connectors**

Each of the four TDM E1 links uses two 75 ohm BNC connectors (refer to figure 2-6), one for transmit and one for receive. These connectors are electrically isolated from the front panel (the shield of the connector is not connected to chassis ground). The shield of the connector is RING and the center conductor is TIP.

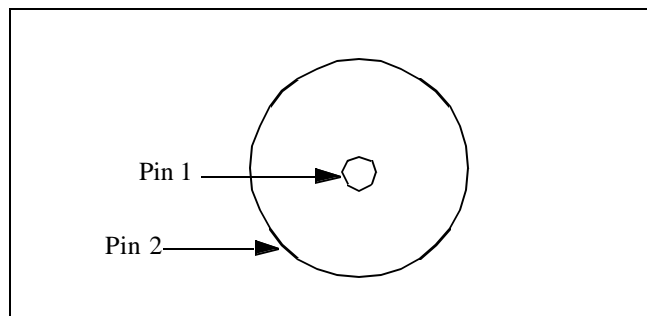

**Figure 2-6. 75ohm BNC Connector**

**Table 2-7. TDM E1 Port 0 Connector Pin Assignments**

Pin	CPCI-816 Signal	Description
2	RvRing0	Receive Ring 0
1	RvTip0	Receive Tip 0
2	TvRing0	Transmit Ring 0
1	TvTip0	Transmit Tip 0

**Table 2-8. TDM E1 Port 1 Connector Pin Assignments**

Pin	CPCI-816 Signal	Description
2	RvRing1	Receive Ring 1
1	RvTip1	Receive Tip 1
2	TvRing1	Transmit Ring 1
1	TvTip1	Transmit Tip 1

**Table 2-9. TDM E1 Port 2 Connector Pin Assignments**

Pin	CPCI-816 Signal	Description
2	RvRing2	Receive Ring 2
1	RvTip2	Receive Tip 2
2	TvRing2	Transmit Ring 2
1	TvTip2	Transmit Tip 2

**Table 2-10. TDM E1 Port 3 Connector Pin Assignments**

Pin	CPCI-816 Signal	Description
2	RvRing3	Receive Ring 3
1	RvTip3	Receive Tip 3
2	TvRing2	Transmit Ring 3
1	TvTip2	Transmit Tip 3



## CHAPTER 3

# FEP INITIALIZATION & BUILT-IN SELF TEST

### 3.1 FEP INITIALIZATION AND BUILT-IN SELF TEST

The CPCI-821 and CPCI-816 boards display on the IOP, ACT, STO and ST1 LEDs the status of the boards initialization and diagnostic self test.

FEP initialization firmware illuminates various user LED patterns after completing early stages of hardware initialization. Should the board fail to boot properly, the LED pattern will indicate the last successfully completed stage of the board initialization sequence. The following table describes the startup LEDs.

**Table 3-1. CPCI-816 Initialization LED Pattern Description**

All LEDs On	Reset Applied
All LEDs Off	Executing Reset vector.
Port 0 Act On Port 0 Lnk On	GT-64130 in single GT mode.
Port 0 Act On Port 0 Lnk On Port 1 Lnk On	SDRAM memory controller initialized.
Port 0 Act On Port 0 Lnk On Port 1 Lnk On Port 1 Act On	MPC8260 internal registers initialized.
Port 0 Act On Port 0 Lnk On Port 1 Lnk On Port 1 Act On Port 2 Lnk On	MMU initialized. Code copied to SDRAM
Port 0 Act On Port 0 Lnk On Port 1 Lnk On Port 1 Act On Port 2 Lnk On Port 2 Act On	Program executing from SDRAM.

## FEP INITIALIZATION & BUILT-IN SELF TEST



All LEDs On	Reset Applied
All LEDs Off	System Level initialization continuing.
Port 3 Act On	MPC8260 CPM reset and initialized. Serial port initialized. Instruction cache enabled. Data cache enabled. Exception vectors initialized. CPCI bridge initialized.
Port 3 ACT On, Port 3 Lnk On	InitBoard Completed. Entering pSOSystem.  LEDs are under application control at this point. TFTP Boot application firmware does not utilize the LEDs.

## CHAPTER 4 PERIODIC MAINTENANCE

### 4.1 PERIODIC MAINTENANCE

The only element of the FEP unit requiring periodic maintenance is the air filter, located on the left hand side of the unit. The filter should be replaced or cleaned every 12 months in normal operating environments. It should be replaced more often in dusty environments.

The replacement of air filter or fan should be done with power off. The fan and air filter assembly is located on the left hand side of the FEP unit. Replacement filters can be purchased from Cyclone Microsystems, Cyclone part number 370-1303.

**Table 4-1. Air Filter Replacement**

1	Loosen the four screws retaining the Fan & Air Filter assembly.
2	Remove the Fan & Air Filter assembly.
3	The air flow element slides out the narrow opening in the Fan & Air Filter assembly. (see Figure 4-1)
4	Slide a new filter element into the narrow opening in the Fan & Air Filter assembly.
5	Install the Fan & Air Filter assembly.
6	Snug the four retaining screws using a Phillips screwdriver.

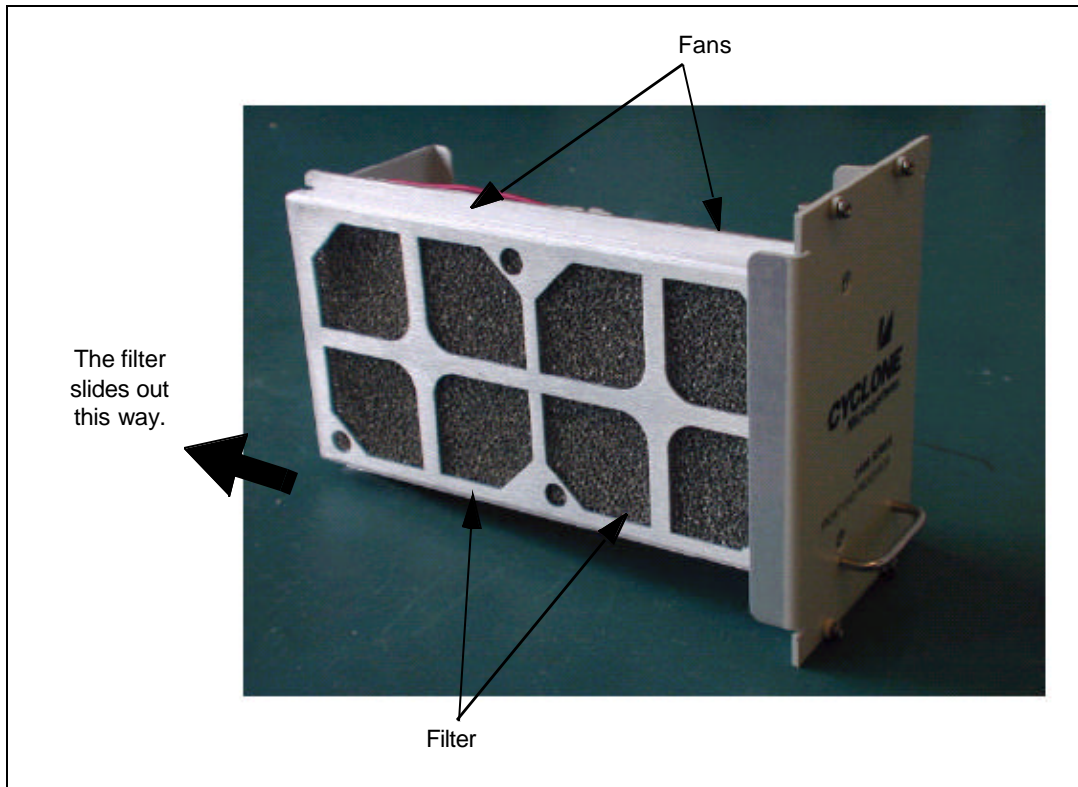

Figure 4-1. Air Filter Replacement

## CHAPTER 5 SERVICEABLE COMPONENTS

### 5.1 SERVICEABLE COMPONENTS

All of the Field Replaceable Units (FRU) of an FEP are serviceable from the front of the unit without the need to dismount an installed FEP from its rack. Table 5-1 lists all the field replaceable units and the associated CLEI codes and Cyclone part numbers.

**Table 5-1. CLEI Number and Barcode**

Cyclone Part Number	Qty	Description	CLEI Number	ECI Code Barcode
<b>600-2400-28-A0</b>				
600-2011	1	5 slot CPCI-AC: 2400 Chassis	GCM2DC0CRA	436787
CM821-064-00-T3	1	CPCI-821 Host Processor Board	GC1PFG0BAA	117503
CM816-064-T3	1	Data Link Board: 4 Port E1	GCP8PKMFAA	113142
370-1302	2	AC Power supply: 2400 Chassis	GCPUHT0JAA	272077
370-1300	1	Fan / Filter Assembly: 2400 Chassis	GCNYAANFAA	436784
370-1303		Filter (only): 2400 Chassis		
<b>600-2400-28-D0</b>				
600-2010	1	5 slot CPCI-DC: 2400 Chassis	GCM2ED0CRA	436788
CM821-064-00-T3	1	CPCI-821 Host Processor Board	GC1PFG0BAA	117503
CM816-064-T3	1	Data Link Board: 4 Port E1	GCP8PKMFAA	113142
370-1301	2	DC Power supply: 2400 Chassis	GCPUCS0JAA	272075
370-1300	1	Fan / Filter Assembly: 2400 Chassis	GCNYAANFAA	436784
370-1303		Filter (only): 2400 Chassis		

### 5.2 BOARD REMOVAL AND INSTALLATION

The CPCI-821 is not hot-swappable and should only be removed or installed with power OFF. All cables should be disconnected from the boards during installation and removal. CPCI 816 Boards are hot swappable and can be removed from the FEP when the power is ON.

#### 5.2.1 Board Removal

FEP Boards can be damaged with electrostatic discharge. Consequently, all boards should be handled in an environment with preventive Electro Static Discharge (ESD) measures. Specifically, boards should only be actively handled with a ground strap and transported in an ESD shielded bag.

Turn power off. Disconnect cables from the board. Loosen the two retaining screws on the boards front panel. The retaining screws are located on each edge of the front panel, between the ejector handles and the end of the front panel. Eject the board by prying outward on both the ejector handles.

### 5.2.2 Board Installation

Insert the board into the FEP unit opening and align the printed circuit board card edge with the card guides inside the unit. Care should be taken to insert the board horizontally (as flat as possible) so as not to interfere with components on the board below or interfere with the underside of the board above. Fully seat the board by pressing firmly on both ejector handles or pressing at the center of the board's front panel.

## 5.3 FAN TRAY REMOVAL AND INSTALLATION

The cooling fans of the FEP are serviceable from the front of the unit. The FEP does NOT have to be removed from its rack to service the fans.

### 5.3.1 Fan / Filter Assembly Removal

Follow steps 1 and 2 in Table 4-1 to remove the Fan/Filter assembly panel. The Fan/Filter assembly is located on the left side of the unit as shown in Figure 4-1. The Fan/Filter assembly has a finger pull. Pull the fan tray from the unit.

### 5.3.2 Fan/Filter Assembly Installation

Align the flanges in the Fan /Filter assembly with its guides after replacing the fan and slide the Fan/Filter access panel into the unit.

## 5.4 POWER SUPPLY REMOVAL AND INSTALLATION

The AC power supply has 2 switches for 2 power supplies and the DC power supply has a single switch for 2 power supplies. The power supplies of the FEP are serviceable from the front of the unit. The FEP does NOT have to be removed from its rack to service the power supplies. The FEP will operate with one power supply installed. Since the power supplies are hot swappable, they can be removed or installed without switching off the power.

### 5.4.1 Power Supply Removal

The two power supplies of the FEP are located above the boards, at the top of the unit. To remove failed power supply, loosen the two retaining screws, at either end of the power supply. Eject the power supply from the FEP by prying outward on the ejector handle. Pull the power supply from the unit.

### 5.4.2 Power Supply Installation

With the printed circuit board of the power supply aligned with the card guides of the FEP unit, slide the power supply into the FEP. Fully seat the power supply and tighten the retaining screws.

## CHAPTER 6

# RELIABILITY PREDICTIONS

### 6.1 METHODOLOGY

Reliability predictions were completed using the Bellcore 5 reliability standard developed by AT&T Bell Laboratories. Component failure rates are calculated based on technology, stress levels, gate or transistor density (ICs), package style, and quality level. Failure rates provided by the component manufacturer have been used in some cases, where available. Failure rates are expressed in FITs, which is failures per billion hours. Mean Time Between Failures (MTBF) is the inverse of the failure rate and is the average time between failures.

### 6.2 ASSUMPTIONS

- Ambient input air temperature does not exceed 30 deg. C.
- Ground, Fixed, Controlled Environment
- Components are Quality Level I.
- Component stress levels do not exceed rated limits (i.e. power dissipation, junction temperature, etc.). In other words, components are used within specification limits. The parts count prediction assumes parts are used at a maximum of 50% of rated electrical stress.
- Component failure could result in FEP failure (except for the power supplies that are configured in parallel redundancy). However, Bellcore's architecture uses FEPs in parallel redundancy.

**6.3 CONFIGURATION**

Item	Part Number	Failure Rate 25°C	MTBF 25°C	Failure Rate 30°C	MTBF 30°C
	<b>600-2400-28-D0</b>	6467	154631	7121	140429
CPCI-821	CM821-064-00-T3	1460	685220	1614	619409
CPCI-816	CM-816-064-T3	2735	365633	3235	309168
DC Power Supply: 2400 Chassis	370-1301	2172	460405	2172	460405
Fan/Filter Assembly: 2400 Chassis	370-1300	100		100	
	<b>600-2400-28-A0</b>	6627	150897	7281	137343
CPCI-821	CM821-064-00-T3	1460	685220	1614	619409
CPCI-816	CM-816-064-T3	2735	365633	3235	309168
AC Power Supply: 2400 Chassis	370-1302	2332	428816	2332	428816
Fan/Filter Assembly: 2400 Chassis	370-1300	100		100	

**6.4 RESULTS**

ITEM	Failure Rate 25°C	MTBF 25°C	Failure Rate 30°C	MTBF 30°C
600-2400-28-D0	6467	154631	7121	140429
600-2400-28-A0	6627	150897	7281	137343



### **7.1 OVERVIEW**

Cyclone Microsystems is a commercial manufacturer of Single Board Computers, Intelligent Communication Controllers and communications systems. Our standard repair cycle for in-warranty or out-of-warranty repair is two weeks. Most of our FEP customers require 24 by 7 support that is far in excess of Cyclone Microsystems' current or anticipated capabilities. Consequently, we highly recommend that FEP customers pursue high availability support from a support organization or pursue an on-site sparing policy in conjunction with a Cyclone Microsystems Expedited Repair Program. Please contact a Cyclone sales representative for a program proposal.

### **7.2 HARDWARE**

Cyclone Microsystems, Inc. (Cyclone) for the period set out below, warrants that its standard products will be free from defects in workmanship or material under normal use and service. Cyclone's obligation under this warranty shall not arise until the Buyer returns the defective product, freight prepaid, to Cyclone. The only responsibilities of Cyclone under this warranty are at its option to replace or repair, without charge, any defective component of such products.

### **7.3 SOFTWARE AND FIRMWARE**

Cyclone warrants that Software and Firmware supplied shall conform to the then current published documentation applicable to such programs. Cyclone, for the effective period of the warranty set out below, will upon written notice from the Buyer documenting the symptoms or the defect, expend its best efforts to resolve software bugs and/or fault. This service shall be without extra charge, and at Cyclone's option may include on-site visit(s) if in its opinion the conditions justify such visit(s).

### **7.4 EFFECTIVE PERIOD OF WARRANTY**

One year from date of delivery.

### **7.5 REPAIRED OR REPLACEMENT PRODUCT (OUT-OF-WARRANTY)**

Cyclone Microsystems, for a period of 30 days, warrants that its out-of-warranty products that are repaired or replaced shall be free from defects in workmanship or material under normal use and service.

Any repair or replacement shall not extend the period within which the warranty can be asserted.

The above warranties do not extend to and shall not apply to:

- Products which have been repaired or altered by other than Cyclone, unless the Buyer has properly altered or repaired the products in accordance with procedures previously approved, in writing, by Cyclone; or
- Products which have been subject to misuse, neglect, accident or improper installation; or

## WARRANTY



- Products not manufactured by Cyclone.

**The foregoing warranty and remedies are exclusive and are made in lieu of all other warranties express or implied, either in fact or by operation of law, statutory or otherwise, including warranties of merchantability and fitness for use. Cyclone neither assumes nor authorizes any other person to assume for it any other liability in connection with the sale, installation or use of its products, and Cyclone makes no warranty whatsoever for products not manufactured by Cyclone or with respect to any non-standard products which have been subject to misuse, neglect, accident, or have been modified by the Buyer. Cyclone shall have no liability for incidental or consequential damages of any kind arising out of the sale, installation, or use of its products.**

### 7.6 SERVICE POLICY

Out of repair warranty will be accomplished expeditiously at a charge published on the current price schedule plus shipping. A full description of the failure must be enclosed with the product.

Shipments arriving at Cyclone without a Return Material Authorization (RMA) number will not be accepted and will be returned to the customer at his cost regardless of warranty status.

#### Return Procedures

Upon determining that repair is required, the customer must:

- Call Cyclone Customer Support at (203) 786-5536 for a RMA number. Please have ready:
  - The serial number of the board (s)
  - The reason for return
- Enclose a detailed description of the failure with the failed unit in a static-shielded protective container.
- Ship unit to: Cyclone Microsystems, 25 Science Park, New Haven, CT 06511, Attn: RMA number
- The RMA is valid for 30 days after issue.



## APPENDIX A MANUALS

### A.1 ADDITIONAL INFORMATION

Additional information for each of the boards used in the FEP can be found in their respective User's Manual. These manuals are available from Cyclone Microsystems.

<b>Part Number</b>	<b>Description</b>
800-0821	CPCI-821 User's Manual
800-0816	CPCI-816 User's Manual